



Australian Government

Australian Transport Safety Bureau

ATSB TRANSPORT SAFETY INVESTIGATION REPORT

Technical Analysis Occurrence Report – 200601173

Final

Microlight Structural Analysis
Airborne Edge
Aircraft Registration: 32-4456 and 32-4388



Australian Government

Australian Transport Safety Bureau

ATSB TRANSPORT SAFETY INVESTIGATION REPORT

Technical Analysis Occurrence Report

200601173

Final

Microlight Structural Analysis
Airborne Edge
Aircraft Registration: 32-4456 and 32-4388

Published by: Australian Transport Safety Bureau
Postal address: PO Box 967, Civic Square ACT 2608
Office location: 15 Mort Street, Canberra City, Australian Capital Territory
Telephone: 1800 621 372; from overseas + 61 2 6274 6590
Accident and serious incident notification: 1800 011 034 (24 hours)
Facsimile: 02 6274 6474; from overseas + 61 2 6274 6474
E-mail: atsbinfo@atsb.gov.au
Internet: www.atsb.gov.au

© Commonwealth of Australia 2006.

This work is copyright. In the interests of enhancing the value of the information contained in this publication you may copy, download, display, print, reproduce and distribute this material in unaltered form (retaining this notice). However, copyright in the material obtained from non-Commonwealth agencies, private individuals or organisations, belongs to those agencies, individuals or organisations. Where you want to use their material you will need to contact them directly.

Subject to the provisions of the *Copyright Act 1968*, you must not make any other use of the material in this publication unless you have the permission of the Australian Transport Safety Bureau.

Please direct requests for further information or authorisation to:

Commonwealth Copyright Administration, Copyright Law Branch
Attorney-General's Department, Robert Garran Offices, National Circuit, Barton ACT 2600
www.ag.gov.au/cca

ISBN Microlight Structural Analysis, Airborne Edge, Aircraft Registration: 32-4456 and 32-4388.

CONTENTS

THE AUSTRALIAN TRANSPORT SAFETY BUREAU	v
EXECUTIVE SUMMARY	vi
1 FACTUAL INFORMATION	1
1.1 Background.....	1
1.2 Parts Received	1
1.3 Assembly Information	2
1.3.1 Wing Construction.....	2
1.3.2 Base Construction.....	3
1.4 In-flight operation.....	3
1.5 Examination.....	4
1.5.1 Wingspar.....	4
1.5.2 Load and Design Examination.....	6
1.5.3 Hexham Accident	6
1.5.4 Material Specifications	7
1.5.5 Propeller.....	7
1.5.6 Fabric Examination.....	10
2 ANALYSIS	12
2.1 Failure Analysis	12
2.2 Material Characterisation.....	13
2.3 Propeller Failure	13
2.4 Wing Fabric	13
3 FINDINGS.....	14
3.1.1 Contributing Safety Factors	14
3.1.2 Other Key Findings.....	14

DOCUMENT RETRIEVAL INFORMATION

Report No.	Publication date	No. of pages	ISBN	ISSN
200601173	November 2006	23		

Publication title

Microlight Structural Analysis, Airborne Edge, Aircraft Registration: 32-4456 and 32-4388

Author(s)

Ferdinand, Dinukshi N., Reviewed by Blyth, Neville R.

Prepared by

Australian Transport Safety Bureau
PO Box 967, Civic Square ACT 2608 Australia
www.atsb.gov.au

Abstract

During the investigation of two fatal microlight accidents, Recreational Aviation Australia (RA-AUS) requested the assistance of the Australian Transport Safety Bureau (ATSB) in conducting technical examination and analysis of parts recovered from the accident sites.

The first accident occurred in Atherton, Qld (registration 32-4456) on 20 October 2005 and the second in Cessnock, NSW (registration 32-4388) on 21 January 2006. During the course of the investigation a third fatal accident was identified. The third accident had occurred in Hexham, NSW (registration T2-2625) in 1996, with coronial findings (0063/96) delivered on 25 March, 1997.

In all three accidents, the failure of the main wingspar had occurred near the wingtip. Qualitative analysis of the structural design and loading of the part during this safety investigation and examination of the coronial findings from the Hexham accident, revealed that the main wingspar had failed under negative 'G' loading. Such loading was likely if the aircraft entered or encountered flight conditions outside the manufacturer's specified flight envelope.

THE AUSTRALIAN TRANSPORT SAFETY BUREAU

The Australian Transport Safety Bureau (ATSB) is an operationally independent multi-modal Bureau within the Australian Government Department of Transport and Regional Services. ATSB investigations are independent of regulatory, operator or other external bodies.

The ATSB is responsible for investigating accidents and other transport safety matters involving civil aviation, marine and rail operations in Australia that fall within Commonwealth jurisdiction, as well as participating in overseas investigations involving Australian registered aircraft and ships. A primary concern is the safety of commercial transport, with particular regard to fare-paying passenger operations. Accordingly, the ATSB also conducts investigations and studies of the transport system to identify underlying factors and trends that have the potential to adversely affect safety.

The ATSB performs its functions in accordance with the provisions of the *Transport Safety Investigation Act 2003* and, where applicable, relevant international agreements. The object of a safety investigation is to determine the circumstances to prevent other similar events. The results of these determinations form the basis for safety action, including recommendations where necessary. As with equivalent overseas organisations, the ATSB has no power to implement its recommendations.

It is not the object of an investigation to determine blame or liability. However, it should be recognised that an investigation report must include factual material of sufficient weight to support the analysis and findings. That material will at times contain information reflecting on the performance of individuals and organisations, and how their actions may have contributed to the outcomes of the matter under investigation. At all times the ATSB endeavours to balance the use of material that could imply adverse comment with the need to properly explain what happened, and why, in a fair and unbiased manner.

Central to the ATSB's investigation of transport safety matters is the early identification of safety issues in the transport environment. While the Bureau issues recommendations to regulatory authorities, industry, or other agencies in order to address safety issues, its preference is for organisations to make safety enhancements during the course of an investigation. The Bureau is pleased to report positive safety action in its final reports rather than make formal recommendations. Recommendations may be issued in conjunction with ATSB reports or independently. A safety issue may lead to a number of similar recommendations, each issued to a different agency.

The ATSB does not have the resources to carry out a full cost-benefit analysis of each safety recommendation. The cost of a recommendation must be balanced against its benefits to safety, and transport safety involves the whole community. Such analysis is a matter for the body to which the recommendation is addressed (for example, the relevant regulatory authority in aviation, marine or rail in consultation with the industry).

EXECUTIVE SUMMARY

Recreational Aviation Australia (RA-Aus) Inc, is an administrating body for microlight aviation in Australia. As part of its work, RA-Aus conducts safety investigations into microlight incidents and accidents.

During the investigation of two fatal accidents, the RA-Aus requested assistance from the Australian Transport Safety Bureau (ATSB) in conducting the technical examination and analysis of parts and components recovered from the accident sites, to assist the RA-Aus in compiling their final report.

The first accident occurred in Atherton, Qld (registration 32-4456) on 20 October 2005 and the second in Cessnock, NSW (registration 32-4388) on 21 January 2006. During the course of the investigation a third fatal accident was identified. This had occurred in Hexham, NSW (registration T2-2625) in 1996. The Hexham coronial findings (0063/96) were delivered on 25 March, 1997 and were used to establish that this accident was similar in nature to that in Atherton and Cessnock.

In all three accidents, the failure of the main wingspars (Airborne Edge design) had occurred near the wingtip. Qualitative analysis of the structural design and loading of the part during this safety investigation and the examination of the coronial findings from the Hexham accident, revealed that the main wingspar had failed under negative G loading. Such loading was likely if the aircraft entered or encountered flight conditions outside of the manufacturer's specified flight envelope. Examination of material characteristics of the failed wingspars did not show evidence of material deficiencies that could have contributed to these accidents.

1 FACTUAL INFORMATION

1.1 Background

An Airborne Edge microlight aircraft, registration 32-4456, impacted terrain on 20 October 2005 during a flight to Atherton, in Far North Queensland. The pilot, the sole occupant of the aircraft, was fatally injured.

A similar Airborne Edge aircraft, registered 32-4388, impacted terrain on 21 January 2006 at Cessnock, New South Wales, also fatally injuring the pilot, the sole occupant of the aircraft.

In both instances, Recreational Aviation Australia (RA-Aus) initiated safety investigations to determine contributing factors to these accidents. During the course of these investigations, similarities in the structural failures of both aircraft were observed. In addition, a third accident involving an Airborne aircraft with similar structural failure was identified. This accident had occurred in 1996 in Hexham, NSW (aircraft registration T2-2625).

In order to determine possible connections between all three accidents, the Australian Transport Safety Bureau (ATSB) was asked to conduct technical examination and analysis on recovered parts from 32-4456 and 32-4388, to assist the RA-Aus investigation. Information regarding the accident involving T2-2625 was taken from Coronial Findings 0063/96, delivered on 25 March, 1997.

1.2 Parts Received

Parts received from 32-4456 wreckage:

- Mylar leading-edge cover
- Fabric sample purple
- Fabric sample white
- Left-side rear leading-edge wingspar A
- Left-side rear leading-edge wingspar B
- Left-side wingtip battens
- Right-side rear leading-edge wingspar.

Parts received from 32-4388 wreckage:

- Propeller and hub
- Right side knuckle, base bar and trim assembly
- Mast, engine mount lower end
- 'A' frame Right-side top
- 'A' frame Left-side top
- Mast, top-mast end upper
- Left side knuckle, basebar assembly
- Stainless steel bracket cables
- Right-side rear leading-edge wingspar A
- Right-side rear leading-edge wingspar B.

1.3 Assembly Information

1.3.1 Wing Construction

The Airborne Edge microlight wing ('Streak' airframes) consisted of a fabric-covered, wire-braced tubular aluminium structure. The fabric cover provided the lifting surface and the wire-braced tubular aluminium alloy framework, provided the load-bearing structure, see figure 1.

Figure 1: Microlight wing construction¹ typical of a Streak airframe.

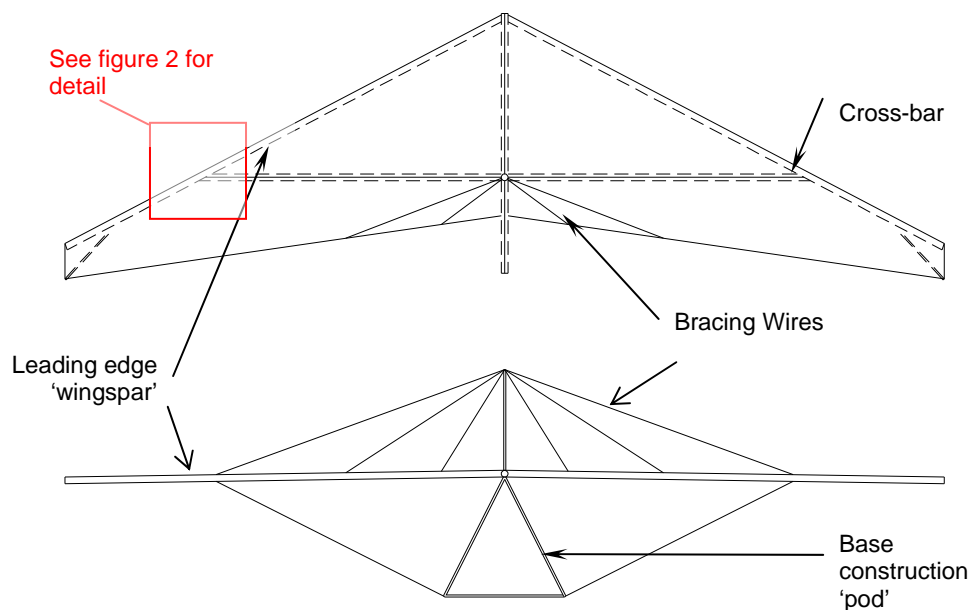

¹ Note: the structure presented is approximate and for illustrative purposes only. Refer to documentation from the microlight manufacturer for detailed construction information.

The aerofoil shape of the fabric was maintained with a series of battens (not shown in figure 1) running fore-aft from the leading-edge wingspar to the trailing edge.

The wire bracing extended out to the intersection of the cross bar and leading-edge wingspar. At this point, the leading-edge wingspar had been reinforced by an internal sleeve of tubular aluminium alloy, see figure 2.

Figure 2: Leading-edge wingspar with reinforcing sleeve.

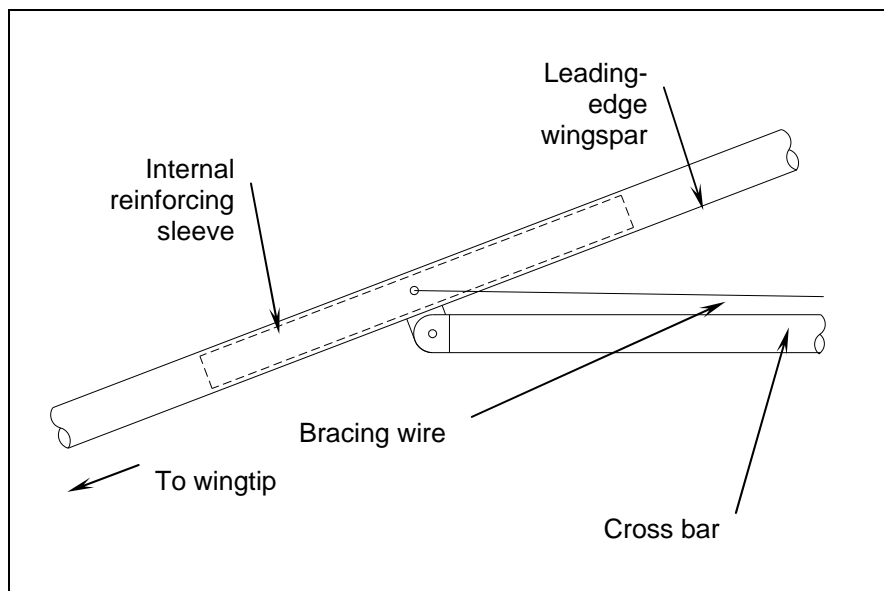

1.3.2 Base Construction

The microlight base construction for both 32-4456 and 32-4388 consisted of a two seat (in-line), weight-shift control trike. The pilot passenger 'pod' was suspended by a triangular frame, hinged from the mast head about the pitch and roll axes, to provide weight shift control.

The power system for 32-4456 was a two-stroke Rotax engine and for the 32-4388, a four-stroke Rotax engine. Both aircraft incorporated a push propeller (i.e. as the rear of the cockpit)

1.4 In-flight operation

The manufacturer's operating handbook prohibited all aerobatic manoeuvres including whipstalls, stalled spiral descents and negative G manoeuvres. The manual specified that the nose of the aircraft should not be pitched up or down more than 45 degrees, that the front support tube of the microlight and the pilot's chest limit the fore and aft movement of the control bar, and that the aircraft should not exceed a bank angle of 60 degrees.

1.5 Examination

1.5.1 Wingspar

32-4456

The left and right rear leading-edge wingspar (Streak 1 airframe) for 32-4456 were received and examined. The spar tube (tip) had a wall thickness of 1.2 mm and the location of fracture of the left spar was 1.43 m from the left wing tip, see figure 3. The fracture occurred transversely through the tubular section, at the insertion of the reinforcing sleeve. The fracture site showed typical characteristics of bending (i.e. the thin-walled tubular section had collapsed) with evidence of tearing of the aluminium tube, see figure 4. The concave surface of the collapsed section was located on the underside of the spar, indicating a downward bending load (normal to the plane of the wing). There was no evidence of defects or pre-existing cracks that could have contributed to the failure of this component.

Figure 3: Location of the fractures fore 32-4456 and 32-4388. Note: both occurred through the outer end of the internal reinforcing sleeve. Diagram not to scale.

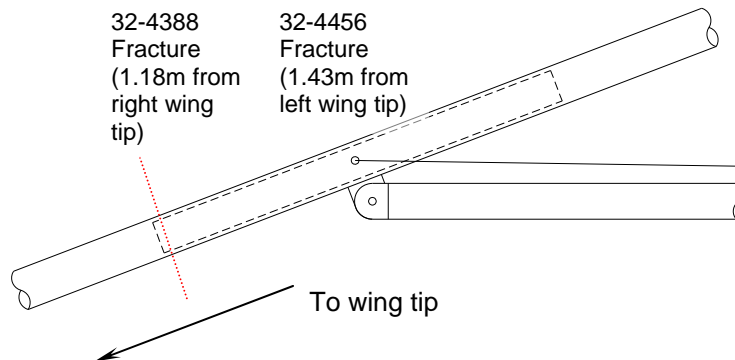

Figure 4: Fracture of the left wingspar of 32-4456.



The intact right wingspar was also supplied for 32-4456 and was bowed along its length, approximately 25 mm from its standard longitudinal axis. The concave surface was the underside section of the spar, again indicating a downward bending load, normal to the plane of the wing. Small dents were observed on both sections recovered from 32-4456.

32-4388

Examination of the fractured right wing spar from 32-4388 (Streak 3 airframe) showed similar fracture characteristics to 32-4456. The fracture occurred 1.18 m from the right wing tip, at the outer end of the internal reinforcing sleeve, and evidence of bending and tearing of the tubular section was observed, see figure 5. Unlike the fracture of 32-4456, the fracture surface was angled, indicating a downward bending load (normal to the plane of the wing) and rearward load (i.e. parallel to the plane of the wing). Small dents in the wingspar were observed along its length. There was no evidence of pre-existing defects or prior cracks that could have contributed to the failure of this component.

Figure 5: Fractured right wing spar of 32-4388. Note buckling and tearing features of the fracture and the 'slant' of the fracture.



1.5.2 Load and Design Examination

The spanwise lift distribution on an untwisted wing is approximated by finding the average between an 'ideal' elliptical distribution and the chord distribution as seen in figure 6. The area under each curve is equivalent to the entire lift loading and the two distributions are thus made equal for the approximation.

Figure 6: Wing spanwise lift distribution.

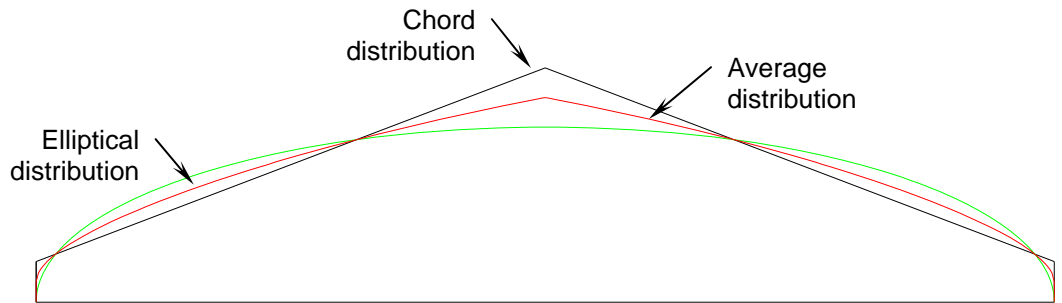

Review of photographs of the Airborne Edge microlight², indicated that the wing adopts a degree of twist while in flight. Twist will effect the load distribution by shifting some of the lift from the tips inboard (i.e. more lift is generated in the middle of the wing). Given the structural restraint of the tip struts and battens located at the tip of the trailing edge of the wing, see figure 7, the aerofoil at the wing tip must adjust and try to align with the relative airflow. This results in a smaller amount of lift generated near the wing tips due to a reduced angle of attack to the relative airflow.

Figure 7: Circled are the wing tip struts that act as structural restraints to the wingspar (battens are not shown in this diagram).

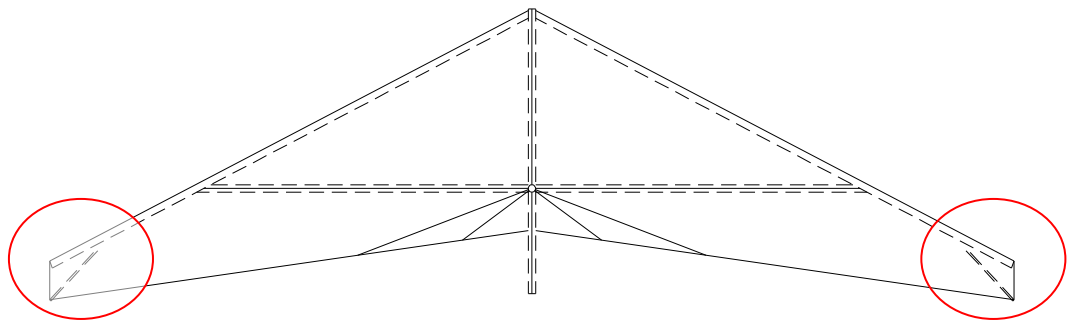

1.5.3 Hexham Accident

Expert witness testimony from coronial findings 0063/96, stated that the Airborne Edge wing structure showed evidence of downward bending.

² www.airborne.com.au

1.5.4 Material Specifications

Material data provided by the manufacturer for the wingspar, specified the material as Aluminium Alloy 6061- T6 temper³.

Representative sections from the tips of the 32-4456 and 32-4388 wingspar were removed and prepared for metallographic examination, see table 1.

Table 1: Metallographic sample identification and location.

Sample ID	Section
1	32-4456 Left wingtip (reinforcing sleeve)
2	32-4456 Left wingtip
3	32-4388 Right wingtip

The microstructure, see figure 8, of all three samples included elongated grains, containing small, black, evenly dispersed particles suspected to be Magnesium Silicide (Mg_2Si).

Figure 8: Microstructure of sample 3. Similar characteristics were observed for samples 1 and 2.



Five Vickers hardness tests were completed for each of the three samples. Hardness ranged between 98HV₅ and 104HV₅ (average 101HV₅). This was typical for Aluminium alloy 6061-T6⁴.

1.5.5 Propeller

The propeller from 32-4388 is shown in figure 9 in its as-received condition. The propeller assembly was identified as a Carbon Fibre- Epoxy, three-blade construction with an aluminium alloy hub. The blades consisted of a glass fibre-epoxy and foam core, with a carbon fibre-epoxy outer surface⁵. For analysis purposes, the three blades were labelled A, B and C, see figure 9. All three blades were able to be rotated within the hub assembly.

³ T6 Temper: Solution heat treated and artificially aged.

⁴ ASM handbook Vol 2 (10th Edn).

⁵ Bolly Products Series Three propeller, www.bolly.com.au

Figure 9: Fractured propeller from 32-4388.



Examination of blade A, the only intact blade, revealed leading edge damage, see figure 10. The damage was predominantly at the tip of the blade and included splitting of the carbon fibre surface and de-bonding of the outer coating. There was no observed fibre pull out at this location.

Figure 10: Leading edge damage to blade A.



Blade B included a stepped fracture surface and glass fibre pull out was observed. The pull out was longer on one side of the fracture than the other, arrowed in figure 11. The fracture characteristics of the foam core showed two distinct fracture regions, a smooth region and a coarse region.

Figure 11: Fracture surface of blade B. Note that fibre pull out is longer on one side of the fracture (arrowed).

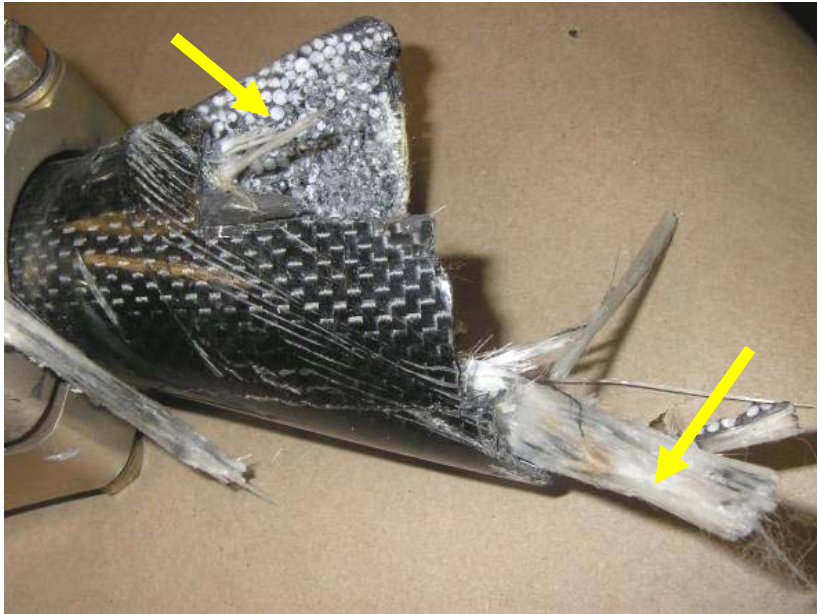

The fracture of blade C was close to the propeller hub and was relatively flat, the inner metal core was visible and glass fibre pull out was observed. Similar to blade B, fibre pull out was longer on one side of the fracture than the other, arrowed in figure 12.

Figure 12: Fracture surface of blade C. Note fibre pull out was more pronounced on one side of the fracture surface (arrowed).



1.5.6 Fabric Examination

Two sections had been taken from the 32-4456 microlight canopy for analysis, see figure 13; a sample of the leading-edge fabric (purple), and a sample from the top surface of the wing, back from the leading edge to the trailing edge (off-white). The purple sample was relatively unsoiled, while the off-white fabric sample included a number of unidentified stains.

Figure 13: Purple and off-white fabric sample taken from the microlight canopy.



Examination of the purple fabric samples, see figure 14, revealed intact, undamaged threads, with no visual evidence of degradation. Examination of the off-white fabric samples showed irregularities in the weave and contamination of the threads, arrowed in figure 15. Those samples were viewed under the light microscope, and areas of damage coincided with stains on the fabric.

Figure 14: Thread condition characteristic of the purple fabric sample at high and low magnifications.

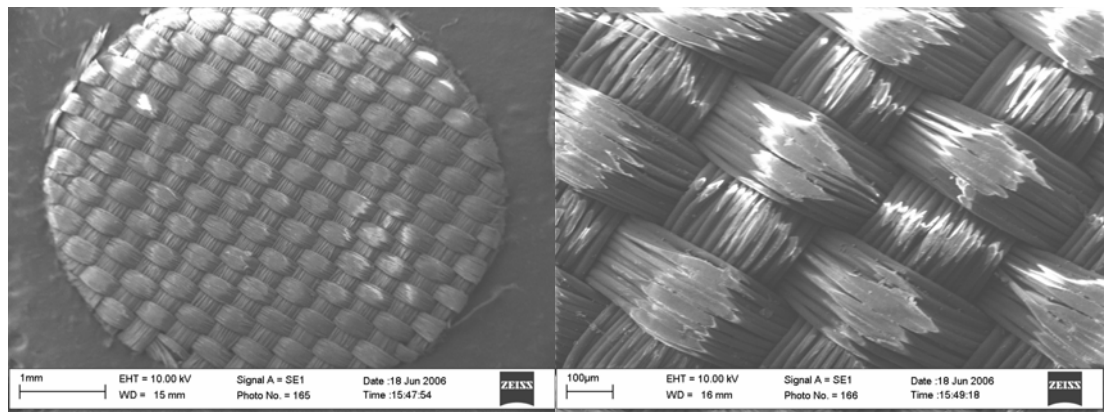
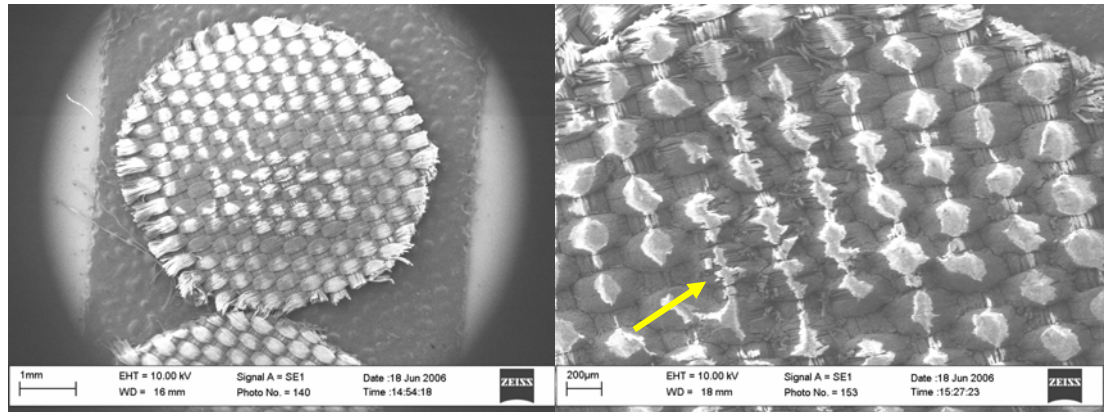

Figure 15: Thread condition characteristic of off-white fabric samples at high and low magnifications. Note the irregularity in the fabric weave.



2.1 Failure Analysis

Examination of leading-edge wingspar failures from 32-4456 and 32-4388, and expert witness statements (Hexham accident) suggested that the applied load on the wingspars was a downward bending moment. Evidence showed the tubes initially failed in compression, resulting in an unstable section collapse. This is typical for a thin-walled circular tube under a bending load. The wingspar from 32-4388 exhibited an angled fracture surface, indicating an additional rearward load during failure.

Review of the Airborne Edge microlight structure indicated that the section of leading-edge beam, outboard of the outer most bracing wire, would effectively act as a cantilever. Figure 16 presents bending moment distribution of a cantilever under this type of loading. The maximum bending moment would occur at the bracing-wire attachment, however the internal reinforcing sleeve would provide a significant amount of support to the beam and thus it is likely in overload conditions that the failure would occur in the main tube at the end of the sleeve, as observed.

Figure 16: Bending moment distribution on a cantilever representation of the wingspar

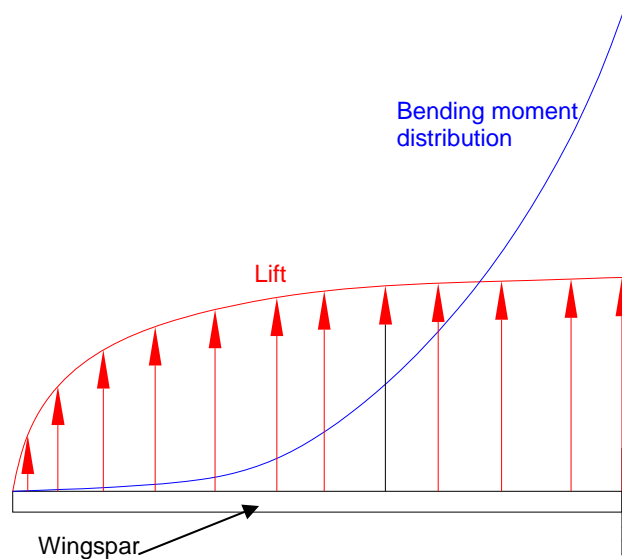

The manufacturer's operating handbook stated that negative G manoeuvres were not permitted. Qualitative analysis of the wingspar structure design and loading suggested that the amount of wing twist and the flexibility of the outer wing were unlikely to account for the amount of load required to lead to the observed failure, when the wing is maintained in the positive G regime.

The structural strength of a thin-wall tube in bending can be significantly degraded by localised damage. For example, a small dent in the lower surface of the tube could reduce the bending strength by a significant factor. For it to have been a factor in this case, the damage would have had to coincide with the end of the

reinforcing sleeve and the wing would still have required a significant downward bending moment applied. Thus, it remains unlikely that the observed failure would have occurred within the approved flight envelope.

2.2 Material Characterisation

The microstructure and hardness results for all three samples taken from the leading-edge wingspars of 32-4456 and 32-4388, were consistent with an Aluminium alloy 6016-T6. They were within the manufacturer's material specifications and there was no evidence of material deficiencies or abnormalities that could have contributed to the failure of the wingspars.

2.3 Propeller Failure

Damage to the tip of blade A from microlight 32-4388 was consistent with being involved in an impact event. Failure of blades B and C were consistent with bending overload failure. Both blades exhibited fibre pullout which was longer on one side of the fracture to the other, suggesting failure under directional bending load. Damage to blade B was consistent with a bending load applied in the direction of rotation, however this could not be established for blade C, as the blade had moved within the hub. It is likely that such loading occurred during an impact event. There was no evidence of mechanical or material defects that could have contributed to the premature failure of the propeller.

2.4 Wing Fabric

Visual examination of the canopy material from microlight 32-4456 showed no evidence of gross abnormalities. The samples representative of the purple fabric section of the microlight canopy were in good condition. Threads were observed to be intact and the weave was regular. The samples representative of the off-white fabric section of the canopy exhibited some irregularities in the weave and damaged threads. These corresponded to stains observed on the fabric. It is likely that these threads were damaged during impact, as dirt was encrusted onto the fabric.

3

FINDINGS

3.1.1 Contributing Safety Factors

Examination and analysis of the Airborne Edge (Streak) microlight structure from 32-4456 and 32-4388, and expert witness testimony for the Hexham accident, identifies downward bending of the wingspar consistent with negative G loading. Such loading may be a result of entering or encountering flight conditions outside the manufacturer's specified flight envelope.

3.1.2 Other Key Findings

Examination and analysis of parts supplied from 32-4456 and 32-4388 showed that:

- Failure of the spars occurred at the point of maximum bending stress of the section (through the internal reinforcing sleeve).
- Fractures of these wingspars were downward/rearward to the plane of the wing. This is consistent with negative G loading of the aircraft.
- There was no evidence of material deficiencies or inconsistencies that could have contributed to the failure of wingspars.